



# PRESSURE RELIEF VALVES: X SERIES

## How It Works

An X-Series PRV from Henry Group works in exactly the same way as a conventional PRV. The significant difference is that the “X” signifies these models have been additionally certified to the EN ISO 4126-1 standard. The main benefit of this is that the PRV will close within 15% of the set pressure following a discharge, meaning that a reduced amount of system change is lost in an overpressure event.

## Material of Construction

The main pressure shell of the valve (body & outlet) is made from brass.

Most internal components are made from brass. However the spring is made from plated steel and the seal is made from a highly resilient and robust fluoroelastomer material.

## Additional Features

- Certified to EN ISO 4126-1
- High Flow Capacity
- Enhanced seat tightness from fluoroelastomer soft seal

## Technical Specifications

All models are fully designed and certified to ASME BPVC XIII and EN ISO 4126-1.

Set Pressure Range:

10.3 barg to 46.0 barg

150 PSig to 667 PSig

Temperature Range:

-40°C to +120°C

-40°F to 248°F

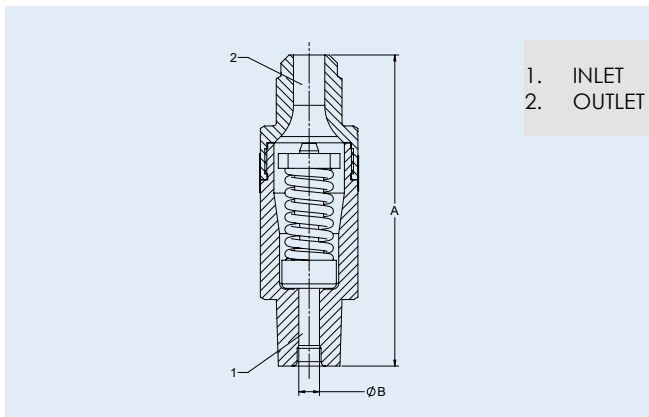

## Installation Instructions



Scan or click the QR Code to download the full product installation and application instructions from our website.



Valve Model / Setting Combinations			
Setting (barg)	5230AX	5231AX	5231BX
20.7			
24.1			
24.8			
25.0			
27.6			
31.0			
40.0			
42.0			
45.0			
46.0			

Note: Blue indicates build to stock models

Part No	Connection Type		Dimensions (mm)		Flow Area (mm <sup>2</sup> )	K <sub>dr</sub>	Weight (kg)	ASME UV	CE/UKCA Cat
	Inlet	Outlet	A	ØB					
	5230AX	1/4" NPTF	1/2" SAE Flare	94					
5231AX	3/8" NPTF	1/2" SAE Flare	94	7.00	38.48	0.77	0.4		
5231BX	1/2" NPTF	5/8" SAE Flare	105	7.00	38.48	0.77	0.4		