



# THREE-WAY DUAL SHUT-OFF VALVES: 93 SERIES

## How It Works

The function of a three-way valve is to permit replacement of one of the pressure relief devices, whilst the other continues to be active on the system. In this way, a vessel is protected from over-pressure during servicing. It also allows a pressure relief device to be replaced in-situ, without removing the system refrigerant charge.

## Applications

Refrigeration standard, EN 378, specifies that a three-way valve is required on vessels of CE Category II, III and IV. EN 378 or an equivalent National Standard should be consulted for further guidance. It should be recognised however that a three-way valve can be fitted to a vessel of any size to enable safe, easy and economical replacement of pressure relief devices.

All 93 series three-way valves are suitable for use with HCFC, HFC, CO<sub>2</sub>, A2L gases and R290 refrigerants along with their associated oils.

The 93 series of three-way valves have been designed to optimise flow efficiency for a given connection size. Designs are fine-tuned using the latest computational analysis and simulation techniques to ensure that the pressure drop upstream of the relief device is minimised. Minimal pressure drop upstream of a PRV in particular is essential to maintain safe and reliable behaviour during a discharge situation. The design utilises a rotatable ball to guide flow and this has the added advantage of allowing both outlet ports access to a full-bore flow area.

## Main Features

- Very high flow capacity (Kvs) for a given connection size
- Maximum full-bore flow on both outlet ports
- Compact geometry minimises required installation space
- “M”, “R” and “MR” models offer Rotalock-style connections on the inlet and/or outlets for optimum angle PRV positioning
- Premium quality PTFE and HNBR sealing materials
- Double O-Ring system seal design
- Blow-out proof design

## Technical Specifications

Allowable operating pressure: 0 to 130 barg

Allowable operating temperature: -40°C to +150°C

## Materials of Construction

The valve bodies and balls are made from brass. The stem is made from plated steel

## Installation - Main Issues

1. If using a female inlet connection model, assemble the three-way valve to a vessel using a high strength pipe nipple, suitable for the maximum operating pressure.
2. The pipework must not impose loads onto the relief assembly. The relief valve, rupture disc and three-way valve assembly should be isolated from piping stresses through proper support, anchoring, or flexibility of the discharge piping. Mechanical piping stresses can be caused by discharge gas forces, misalignment and equipment dead weight. Thermal induced stresses should also be avoided. Appropriate standards such as API 520 Part II should be referenced.
3. Should only be used with a single outlet port fully engaged. Do not leave the valve with both outlet ports partially open as this will impair the flow and can result in insufficient discharge capacity throughout the PRVs.

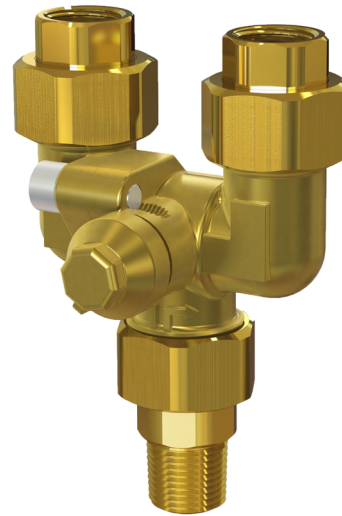

## Rotalock-Style Adaptors

Inlet and outlet Rotalock-style adaptors can be supplied individually. Each adaptor includes the connection, locking nut and PTFE seal. As standard, the 93-series models have female NPT inlet and outlet connections. The addition of a Rotalock-style adaptor expands on the functionality & adaptability of the valve; for example to fit into a small space envelope, or to accurately align the outlet connection of angled PRVs. The adaptors also allow the possibility of a male NPT inlet connection option. Models can be supplied with connections included as shown in the table and figures that follow. The “M” suffix indicates inclusion of the male inlet adaptor, whereas the “R” suffix signifies inclusion of two female outlet adaptors.

Adaptor Description	Part No.
3/8" NPT Female (For 933)	933-ORK
3/8" NPT Male (For 933)	933-IRK
1/2" NPT Female (For 935)	935-ORK
1/2" NPT Male (For 935)	935-IRK

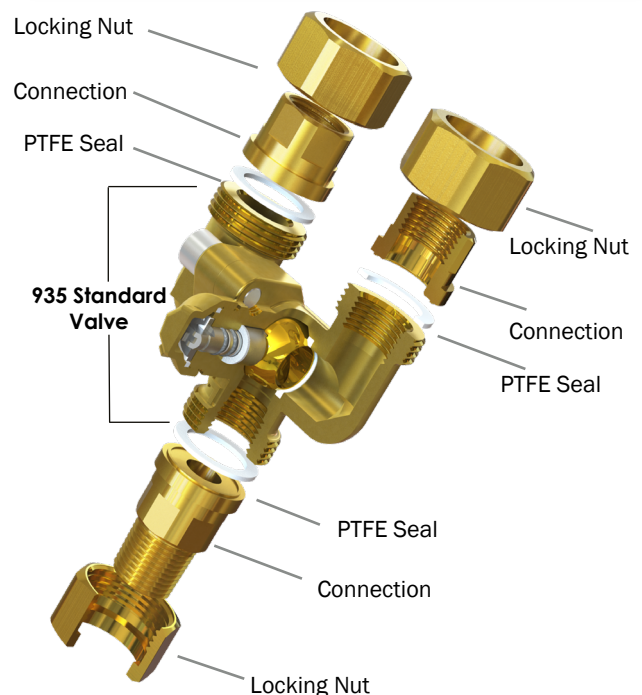



# THREE-WAY SHUT-OFF VALVE

Part No	Inlet Conn (inch)	Outlet Conn (inch)	Adjustment		Dimensions (mm)					Drawing Reference	Weight (kg)	K <sub>vs</sub> Value (m <sup>3</sup> /hr)	CE/UKCA Cat
			Inlet	Outlet	A	B	C	D	E				
933	3/8 NPT (Female)	3/8 NPT (Female)	Fixed	Fixed	56	30	26	31.5	63.0	Fig. 1	0.69	3.68	SEP
933M	3/8 NPT		Rotalock					69.5	101.0	Fig. 2	0.82		
933R	3/8 NPT (Female)		Fixed	Rotalock				31.5	85.0	Fig. 3	0.89		
933MR	3/8 NPT		Rotalock					69.5	123.0	Fig. 4	1.02		
935	1/2 NPT (Female)	1/2 NPT (Female)	Fixed	Fixed	56	30	26	31.5	63.0	Fig. 1	0.67	4.82	SEP
935M	1/2 NPT		Rotalock					75.0	106.5	Fig. 2	0.85		
935R	1/2 NPT (Female)		Fixed	Rotalock				31.5	86.5	Fig. 3	0.91		
935MR	1/2 NPT		Rotalock					75.0	130.0	Fig. 4	1.09		

1. INLET  
2. OUTLET

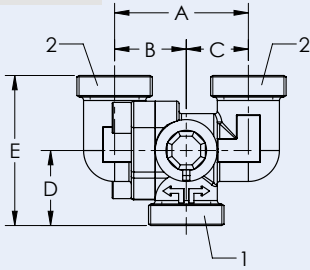

Fig. 1

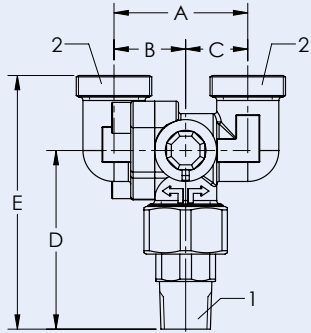

Fig. 2

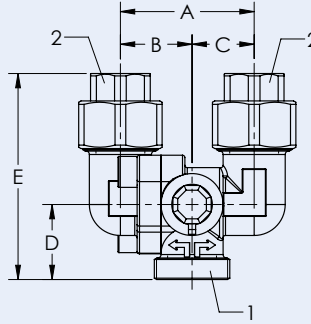

Fig. 3

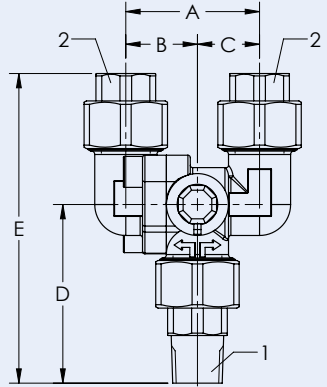

Fig. 4